

RADIOCOMMUNICATION SYSTEMS FOR EARLY WARNING AND DISASTER RELIEF OPERATIONS

Scope

This Recommendation provides technical characteristics and guidelines for governmental wireless systems to be used for early warning and disaster relief operations. Such systems can form a core network connecting a disaster management center (at national or state governments) and local government offices (at local levels such as state, city, town, village) utilizing terrestrial and satellite systems, and also a regional network connecting a local government office and residents utilizing regional simultaneous communication systems (See the figure below.). Several types of systems are recommended to contend with APT member countries' specific circumstances.

Asia Pacific Telecommunity (APT),

Considering

- a)* that radio communications are essential for early warning, disaster mitigation, and relief operations in the event of disasters to deal with a serious disruption of the functioning of society, posing a significant widespread threat to human life, health, property or the environment, whether caused by accident, natural phenomena or human activity;
- b)* that administrations may have various growing needs and requirements for disaster-relief radio communications depending on their circumstances;
- c)* that developing technical characteristics and guidelines for the radio communication systems for early warning and disaster relief would promote a common technical basis in planning of those systems;
- d)* that such systems that have a common basis would benefit cooperation between countries for the provision of effective and appropriate humanitarian assistance in case of disasters, particularly in view of the special operational requirements of such activities involving multinational response,
- e)* that terrestrial and satellite systems should complement each other in support of disaster relief radio communication network;

recognizing

- a)* that **Resolution 646 of World Radiocommunication Conference (Geneva, 2003)** "Public protection

and disaster relief” urges Member States to facilitate use of telecommunications for the safety and security of the personnel of humanitarian organizations;

b) that ITU-R Recommendation F. 1105-1 lists several types of radio communications which are useful in disaster mitigation and relief operations;

c) that particularly Type-F “Regional Simultaneous Communication System” listed in ITU-R Recommendation F. 1105-1 can effectively use the VHF/UHF bands expected to be available after digitization of terrestrial analog television broadcasting in the near future,

recommends

1 that technical characteristics contained in Annexes 1 and 2 be considered in planning and introducing radiocommunication systems for early warning and disaster relief;

2 that guidelines for safety and reliability measures in Annex 3 be referred to as a guide for administrations.

Figure: The topology of network utilizing radiocommunications for disaster management

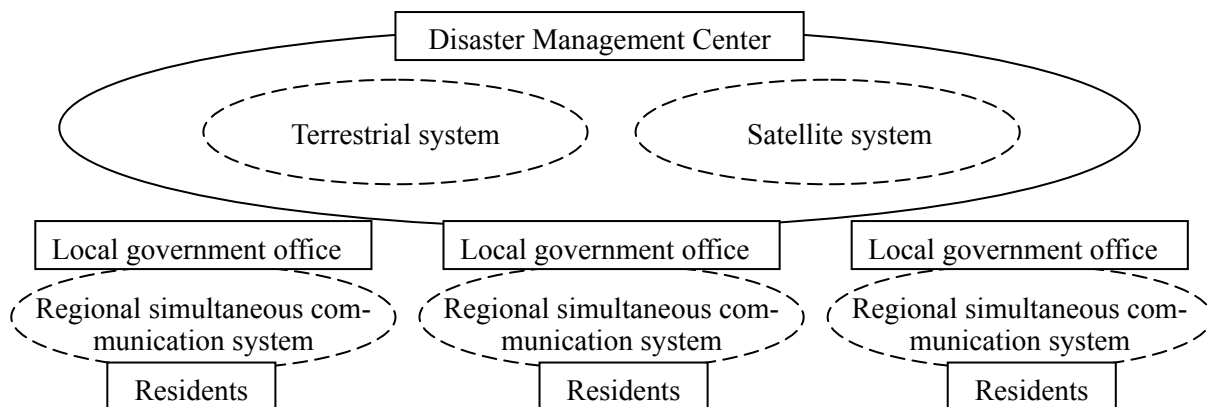

Annexes

Annex 1: System characteristics of Regional Simultaneous Communication System

Annex 2: Core Network System for Disaster Management

-Part 1: Terrestrial network system

-Part 2: Satellite network system

Annex 3: Guidelines for safety and reliability measures on the use of disaster management communication system

ANNEX 1

System Characteristics of Regional Simultaneous Communication System

1 Overview

The Regional Simultaneous Communication System (RSCS) makes it possible for a disaster information center or disaster management center installed in a local government to send disaster information simultaneously and immediately to residents to protect public safety when a disaster occurs.

Disasters to be considered include a wide range: natural disasters such as typhoons, tsunamis, earthquakes, etc.; man-made accidents involving aircraft crashes, nuclear power plant explosions, etc.; and more intentional disasters such as bombings, terrorist attacks, etc. When those disasters occur, it is necessary to immediately notify residents of various kinds of information.

The messages communicated would include, for example, predicted rainfall and wind speed associated with typhoons, or information on tsunamis following earthquakes. Besides these, information on an imminent earthquake, forecasted by using the difference in propagation velocities of primary and secondary waves, may be transmitted. The disaster information may also include notification of evacuation sites. The information basically needs to be broadcast from the disaster information center to residents quickly when a disaster is happening.

The digital system described in this Annex allows bi-directional (two-way) data communication and is equipped with applications that allow gathering of graphic image information from the destruction site and exchanging information between evacuation areas and local governments, as well as applications for issuing voice and message evacuation orders and transmitting disaster messages.

This system is also equipped with applications that provide character display and FAX functions, showing consideration to such physically vulnerable people as the handicapped or the elderly.

Figure 1-1 shows the simultaneous transmission scheme of the disaster information to the Substations, such as Outdoor Terminals and House Receivers, from a Master Station established by the local government. A Relay (or repeater) Station is generally located in a hilly place and relays radiocommunication signals, where direct communications between Master and Substations are geographically difficult.

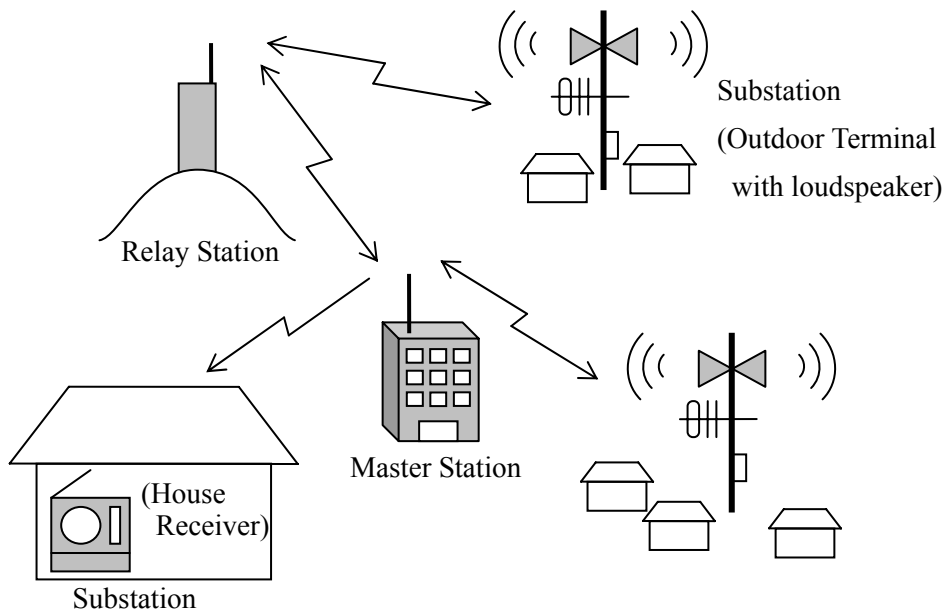

Fig. 1-1 View of a Regional Simultaneous Communication System

2 Basic System Structure

The RSCS consists of a Master Station established by a local government, and Substations. The Relay (or Repeater) Station enables radiocommunication to the areas subject to radio-wave propagation difficulties. The basic structure of the digital RSCS is shown in Fig. 1-2.

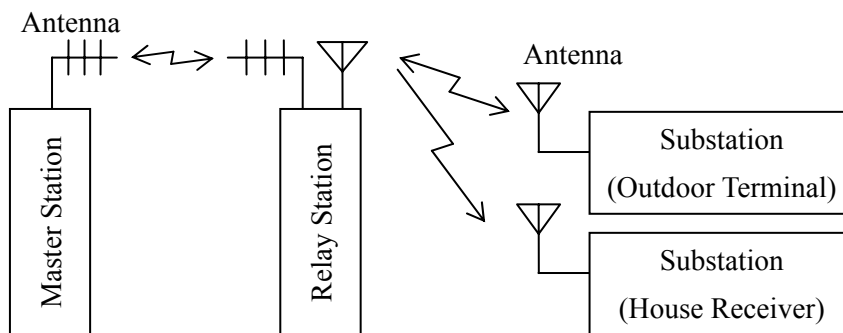

Fig. 1-2 Basic Structure of RSCS

a) Master Station

The Master Station is located in the local government's office.

The Master Station sends voice and message to the Substation and receives voice, image, and data from the Substations.

b) Relay Station

The Relay Station is located in a hilly place to relay radiocommunication signals between the Master Station and the Substations where necessary.

c) Substation

The Substation receives voice and message directly from the Master Station or via a Relay Station. The Substation consists of Outdoor Terminals and House Receivers, both controlled by the Master Station. The Outdoor Terminal can transmit and receive both of communication and command channels; however, the Houser Receiver can only receive a communication channel (for voice and message).

3 System Applications and Features

Applications associated with disaster relief and emergency operations for public protection are the main focus of the system. Applications would also be developed to support a variety of user terminals such as loudspeakers and House Receivers for disaster preparation, relief, and mitigation purposes.

Table 1-1 gives envisioned applications with indication of typical usage examples.

Table 1-1
RSCS Applications and Examples

Application	Examples	Transmitter	Receivers
Voice	Automatic transmission of information on earthquakes, tsunamis, weather information, etc.	Master Station	Outdoor Terminal, House Receiver
	Announcements, alerts and warnings	Master Station	Outdoor Terminal, House Receiver
	Evacuation directions	Master Station	Outdoor Terminal, House Receiver

Application	Examples	Transmitter	Receivers
	Calls for concerned parties	Master Station	Outdoor Terminal, House Receiver
	Reporting damage or gathering disaster information	Outdoor Terminal	Master Station
	Communication with evacuation center or confirmation of safety	Outdoor Terminal	Master Station
Siren	Automatic transmission of information on earthquakes, tsunamis, weather, etc.	Master Station	Outdoor Terminal, House Receiver
	Alerts and warnings	Master Station	Outdoor Terminal, House Receiver
FAX	Automatic transmission of information on earthquakes, tsunamis, weather, etc.	Master Station	Outdoor Terminal, House Receiver
	Announcements, alerts and warnings	Master Station	Outdoor Terminal, House Receiver
	Directions on evacuation	Master Station	Outdoor Terminal, House Receiver
	Calls for concerned parties	Master Station	House Receiver
	Reporting damage or gathering disaster information	Outdoor Terminal	Master Station
	Communication with evacuation centers or confirmation of safety	Outdoor Terminal	Master Station
Characters	Automatic transmission of information on earthquakes, tsunamis, weather, etc.	Master Station	Outdoor Terminal, House Receiver
	Announcements, alerts and warnings	Master Station	Outdoor Terminal, House Receiver
Image and video	Reporting damage or gathering disaster information	Outdoor Terminal	Master Station
	Monitoring rivers, weather, dangerous areas, etc.	Outdoor Terminal	Master Station
	Communication with evacuation centers or confirmation of safety	Outdoor Terminal	Master Station
Data	Automatic transmission of information on earthquakes, tsunamis, weather, etc	Master Station	Outdoor Terminal, House Receiver

Application	Examples	Transmitter	Receivers
	Announcements, alerts and warnings	Master Station	Outdoor Terminal, House Receiver
	Reporting damage or gathering disaster information	Outdoor Terminal	Master Station
	Monitoring rivers (water level), weather (rainfall, wind-force), dangerous areas (land slide), etc.	Outdoor Terminal	Master Station
	Communication with evacuation centers or confirmation of safety	Outdoor Terminal	Master Station

NOTE: The above applications are expected for use both in a disaster and day-to-day communications.

4 System Requirements

4.1 Communication Modes

The system generally has four communication modes, i.e., Simultaneous, Emergency Simultaneous, Group, and Individual communications as shown in Table 1-2, to support the applications in Table 1-1.

Table 1-2
Communication Modes

Communication Mode	Type of Communication
Simultaneous Communication	Simultaneous one-way communication from the Master Station to all standby Substations.
Emergency Simultaneous Communication	One-way communication in an emergency case from the Master Station to all or a group of Substations. In this mode, in order to deliver emergency messages immediately to the residents, the Master Station can occupy communication channels to activate loudspeakers at the Substations, by forcibly disconnecting the communication channels being used.
Group Communication	One-way communication between the Master Station and a group of Substations.
Individual Communication	Bi-directional communication between the Master Station and a specific Substation.

4.2 Simultaneous Use of Multiple Applications

Some RSCS users may require multiple applications (e.g. voice and low/medium speed data) over the network, or others may require a high-speed data transmission to provide activity-intensive services to the damaged area.

The systems serving RSCS should be designed to support the simultaneous use of several different applications as desired by RSCS organizations.

4.3 Application Availability Requirements

The applications in Table 1-1 may become very effective through the proper provision of several communication equipment in the Master Station, Substations and Terminals.

For example,

- The Master Station is provided with FAX, data communication, image transmission and, voice communication equipment,
- The Outdoor Terminals are provided with FAX, data communication, image transmission and voice communication equipment, and
- The House Receiver is provided with audio playback, character display, and FAX equipment.

4.4 Priority Access/Communication Control

As desired by RSCS organizations, the systems serving RSCS should be designed to manage high-priority traffic and low-priority traffic, e.g., by prioritizing emergency communication when a disaster strikes. The RSCS may require the exclusive use of frequencies or equivalent high-priority access over other systems.

5 Radio Station Units

5.1 Master Station

The Master Station may be equipped with two-way transmission units, e.g., FAX communication unit, characters/data/image transmission unit, and voice communication unit as shown in Fig.1-3 to provide bi-directional service.

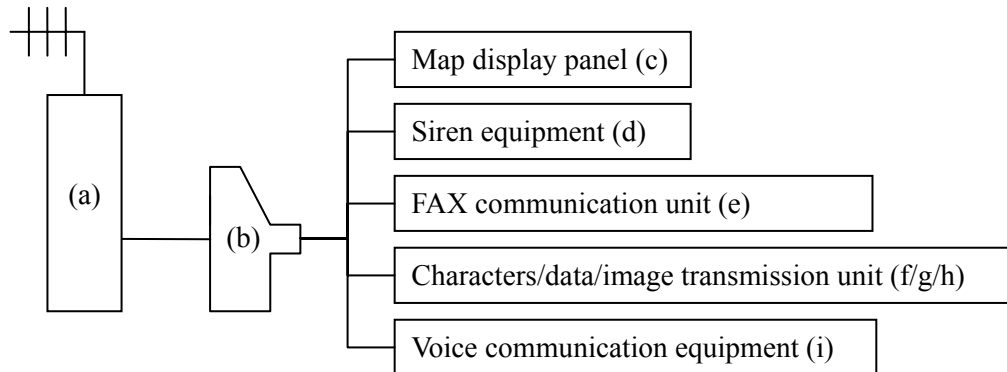

Fig. 1-3 Master Station

a) Transmit-Receive Unit for Master Station

Transmit-Receive Unit for Master Station provides communication controls over the network.

b) Operation Console

The Operation Console is used for handling reports and communications between the Master and Substations. It can monitor and control the Master Station, Relay Station, and Outdoor Terminal with a loudspeaker.

c) Map Display Panel

The Map Display Panel displays the location of the Outdoor Terminals and their operating condition on the map.

d) Siren Equipment

The Siren Equipment generates a siren sound in accordance with blow patterns designating category of alerts, e.g., warning stage (prepare for evacuation), evacuation order, and evacuation directive.

e) FAX Communication Equipment

FAX Communication Equipment provides fax communication between the Master Station, and Outdoor Terminals/House Receivers.

f) Character Transmission Unit

The Character Transmission Unit provides message communications such as fixed or free

phrase service, between the Master Station and the Outdoor Terminal/House Receiver.

g) Data Transmission Unit

The Data Transmission Unit provides data communications between the Master Station and Outdoor Terminal.

h) Image Data Transmission Unit

The Image Data Transmission Unit sends images from digital cameras or monitoring cameras between the Master Station and Outdoor Terminal.

i) Voice Communication Equipment

The Voice Communication Equipment provides bi-directional voice communication between the Master Station and Outdoor Terminal.

5.2 Relay Station

The Relay Station is generally located in a hilly place between the Master Station and Substation to relay radio communications where necessary.

5.3 Substation

5.3.1 Outdoor Terminal

The Outdoor Terminal should receive simultaneous voice and FAX messages from the Master Station, and provide voice communication and image data transmission to the Master Station. The Outdoor Terminal should use the answerback method in which the terminal returns a result of self-check information of the Substation when it receives a request signal from the Master Station. The Outdoor Terminal should have a local broadcast function in the limited area using an accommodated loudspeaker. The Outdoor Terminal should also have bi-directional communication facility for emergency voice communication with the Master Station.

The following equipment can be accommodated in the Outdoor Terminal to execute the applications in Table 1-1 appropriately.

a) Radio Equipment for Outdoor Terminal

This provides a radio communication link between the Master Station and Outdoor Terminal.

b) Loudspeaker

Soon after messages are received from the Master Station, the Outdoor Terminal should activate the loudspeaker to broadcast the received messages.

- c) Character Display Unit
The unit inputs the character information received from the Master Station into the large electro-luminescent display panel or liquid crystal display for reading by the local residents.
- d) FAX Transmission Unit
This unit provides FAX communication between the Outdoor Terminal and the Master Station, and also receives simultaneous FAX message from the Master Station.
- e) Data Transmission Unit
This unit provides data communications between the Outdoor Terminal and Master Station.
- f) Image Data Transmission Unit
This unit sends the video images from a digital camera or monitoring camera of the Outdoor Terminal to the Master Station.
- g) Voice Communication Unit
This equipment provides voice communication between the Outdoor Terminal and Master Station.

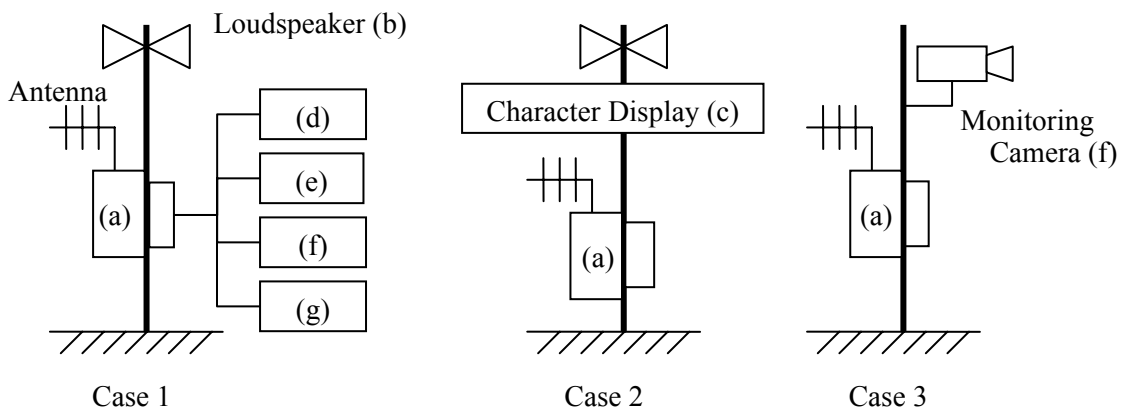

Fig. 1-4 Equipment Pattern Combination on Outdoor Terminals

Case 1: Outdoor Terminal with loudspeaker, Fax/data transmitter and microphone.

Case 2: Outdoor Terminal with loudspeaker and character display.

Case 3: Outdoor Terminal with monitoring camera.

5.3.2 House Receiver

The House Receiver is generally provided to the houses of residents and local government staff. It may be associated with voice playback and character display functions for the information sent from the Master Station. The receiver should work on rechargeable batteries and be operable under disaster conditions. Integrating a commercial FM receiver in the House Receiver will ensure convenience for receiving disaster information broadcasted by local radio.

The following equipment can be connected to the House Receiver in order to support the applications in Table 1-1.

a) Radio Unit for House Receiver

This unit receives control signals and simultaneous voice messages from the Master Station.

b) Automatic Recording Equipment (Voice Playback Device)

For the purpose of confirmation, this equipment automatically records information from the Master Station and reproduces audio messages from the Master Station.

c) Character Display Unit

This unit displays character information received from the Master Station on the liquid crystal display.

d) FAX Transmission Unit

This unit receives and prints out FAX information from the Master Station.

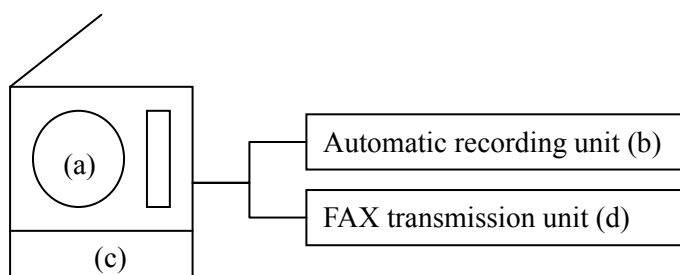

Fig. 1-5 House Receiver

6 Technical Specifications

6.1 Frequency Band

For the digital RSCS, the VHF/UHF bands are preferable considering the service area and radio wave propagation.

6.2 Channel Spacing

The channel spacing should be 15 kHz.

6.3 Transmit and Receive Frequency Bands

The transmit and receive frequency bands should use the same band.

6.4 Multiple Access Method

TDMA (Time Division Multiple Access) should be used as a multiple access method. Measures to avoid congestion in an emergency situation are required.

6.5 Transmission Speed

An appropriate rate is to be selected to send voice, data, and large volumes of graphic image and movies.

6.6 Output Power

The Master Station and Outdoor Terminals should have sufficient output power capability to ensure reliable disaster information delivery to local-area residents in conjunction careful consideration to minimizing interference with the adjacent countries and areas.

6.7 Modulation Scheme

A modulation scheme should be determined with a view to promoting efficient use of the radio frequency and considering radio wave propagation conditions of the fixed radio system. The 16QAM (Quadrature Amplitude Modulation) is one example.

6.8 QoS (Quality of Service)

The transmission Bit Error Rate (BER) should be better than 1×10^{-4} to provide a communication quality suitable for emergency communications.

7 System Management Function

The system should use a network management interface based on existing open standard protocols, for example, SNMP (Simple Network Management Protocol), which provides the following management performance:

- Execution of operating status monitoring for the equipment connected to the network
- Execution of service status monitoring
- Execution of fault trap and performance management
- Network traffic monitoring
- Specific message recording on the system log

Relay station equipment should include a function to automatically report an aberrant condition. The Outdoor Terminal should provide answerback to self-checking in accordance with the monitoring request from the Master Station.

Appendix A to ANNEX 1

System Specifications used in Japan

This appendix gives RSCS technical specifications in Japan as a typical example. The system is based on ARIB STD-T86* and included in Recommendation ITU-R F.1105.

A.1 Transmitter

Frequency band	60 MHz band
Channel spacing	15 kHz
Multiple access method	TDMA (Time Division Multiple Access)
Transmission method	TDD (Time Division Duplex)
Transmission speed	≤ 45 kbps
Multiplication	6 multiplexing
Output power	≤ 10 W
Modulation scheme	16QAM (Quadrature Amplitude Modulation)

A.2 Receiver

Frequency band	54 – 70 MHz band
Sensitivity	≤ +9 dBμV (BER: 1×10^{-2} , no fading)

* http://www.arib.or.jp/english/html/overview/itu/itu-arib_std-t86v1.0_e.pdf

Appendix B to ANNEX 1

Basic System Configuration Patterns of RSCS

B.1 Basic Structure Pattern 1

Figure 1 shows a simplest system structure, consisting of the Master Station and Substation.

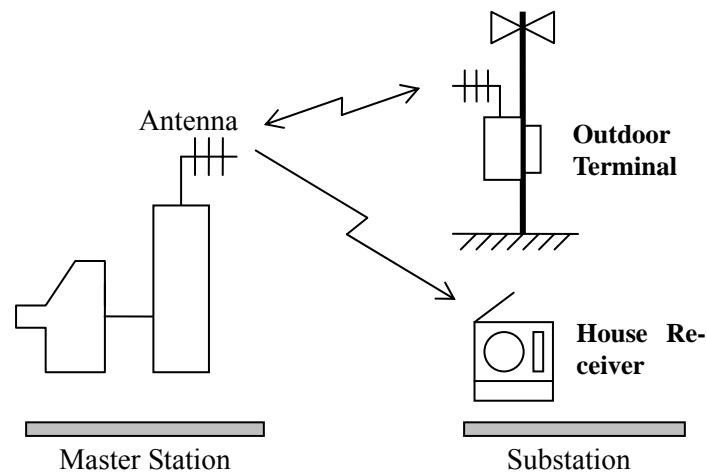

Fig. 1 Basic Structure Pattern 1

B.2 Basic Structure Pattern 2

This pattern consists of the Master Station, Substation, and the Relay Station.

Figure 2 shows a case where the Relay Station is located between the Master and Substations, and each Substation does not receive/send information directly from/to the Master Station.

Figure 3 shows the most probable case where the Substation receives/sends information from /to the Master Station, or via a Relay Station.

The maximum number of signal repetitions is limited to three in order to avoid degradation in signal quality and to ensure proper answerback from the Substation.

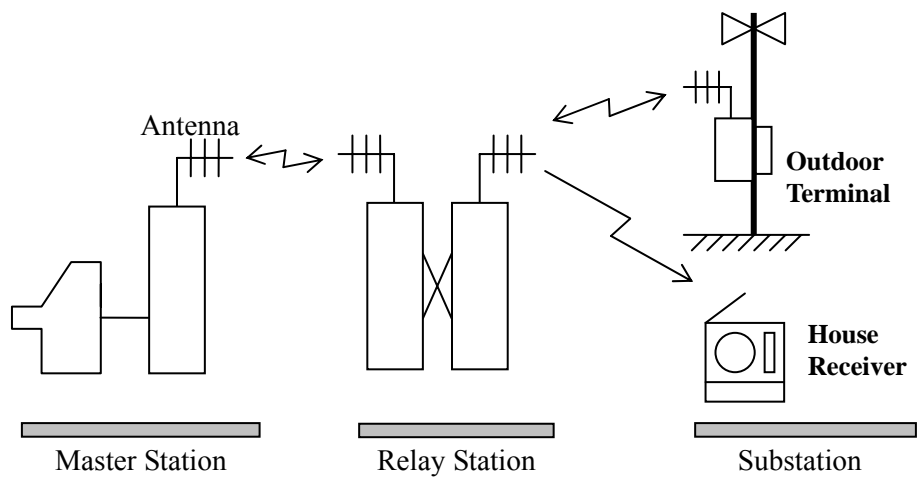

Fig. 2 Basic Structure Pattern 2

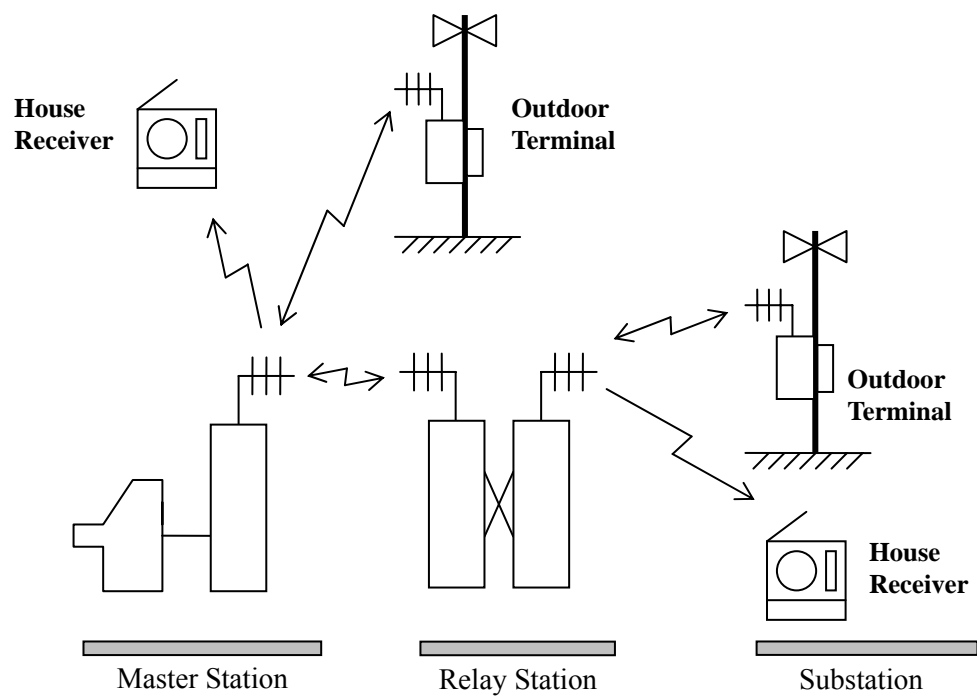

Fig. 3 Basic Structure Pattern 2 with probable Case Scenario

ANNEX 2

Core Network System for Disaster Management

1 Overview

The Core Network System for Disaster Management makes it possible to gather and send rapidly and adequately disaster information of voice, FAX, image picture and data, which connects the local (prefecture) government operating as Disaster Management Center, lower-level local governments, and concerned authorities. This system consists of a terrestrial system and a satellite system comprising earth and space stations. A hybrid system architecture combining terrestrial and satellite systems can provide communication redundancy and thus improve network credibility.

The core network system provides a stable and secure high-speed communication link for transmitting data, images, voice, FAX, etc. between the Control Station (located in a local government) and branch offices in normal times as well as in times of disaster.

Annex2 details the recommended terrestrial and satellite communication systems in Part 1 and 2, respectively.

PART 1

Terrestrial Network System

1 Overview

The terrestrial network system for disaster management is a broadband radio communication network performing data collection and transfer of essential disaster information between local governments in the prefecture (or province), cities, towns, and villages. For prevention and mitigation of damage by such disasters as an earthquake, storm or flood, the terrestrial network system is used to exchange data, image and voice information within the network concerning the disaster to enable initiating appropriate countermeasure activities, and to quickly respond to requests from the Disaster Management Center.

2 Basic System Structures

As shown in Figure 2-1-1, the network consists of a Control Station (located in a prefectural government), Branch Stations, and Terminal Stations. A relay (or repeater) station is generally located in a hilly place and relays radiocommunication signals, where direct communication between the Control Station and other stations is geographically difficult.

The Control and Branch Stations are connected to the digital multiplex radio link that is capable of sending large-volume data. The Branch Station and Terminals are connected to the digital narrow-band radio link that can send small-volume data such as voice and FAX.

2.1 Radio Stations

a) Control Station

The Control Station is a core radio station of the entire terrestrial network system. A Disaster Management Center to assist disaster sites is generally set up in the control station to collect information and provide disaster warning or relief orders to other stations/offices.

b) Branch Station

The branch station distributes the information sent from the Control Station to the Terminals, and returns the information gathered by the Terminals back to the Control Station.

c) Relay (Repeater) Station

The Relay Station's purpose is to ensure coverage of such wide areas as a prefecture or state to provide stable, high-quality radio links. The Relay Station is furnished with digital multi-

plex radio equipment and narrow-band digital radio equipment. The Control Station and relay stations form a looped radiocommunication link that provides reliable communication through alternative radio routes. The Control Station manages the major equipment of the relay through with its long-distance supervising function.

d) Terminal Station

The Terminal Stations are located in a lower-level local (e.g., city) government and concerned authorities. The Terminal Station is connected to the Branch Station by the narrow-band digital radio link that provides telephone and FAX communication.

2.2 Radio Links

Figure 2-1-2 shows the typical equipment configuration of the terrestrial radio link.

a) Backbone Line (Microwave multiplex radio link)

The backbone line of the system is a microwave multiplex radio link that connects the Control and Branch Stations via relay stations. The microwave multiplex radio equipment of each station provides a point-to-point digital radio link between any two stations. The range of media signals such as voice, image, and data are multiplexed in each station and transmitted to the other stations. The basic configuration is a point-to-point connection while the multiplexing equipment provides the functions of channel multiplexing and cross-connecting to ensure the efficient use of the backbone network.

b) Branch Line (Narrow-band radio link)

The narrow-band radio link connects the Terminal Stations to the upper-level stations. The link provides telephone and fax channels via digital switching equipment that is located in the Control and Branch Stations respectively.

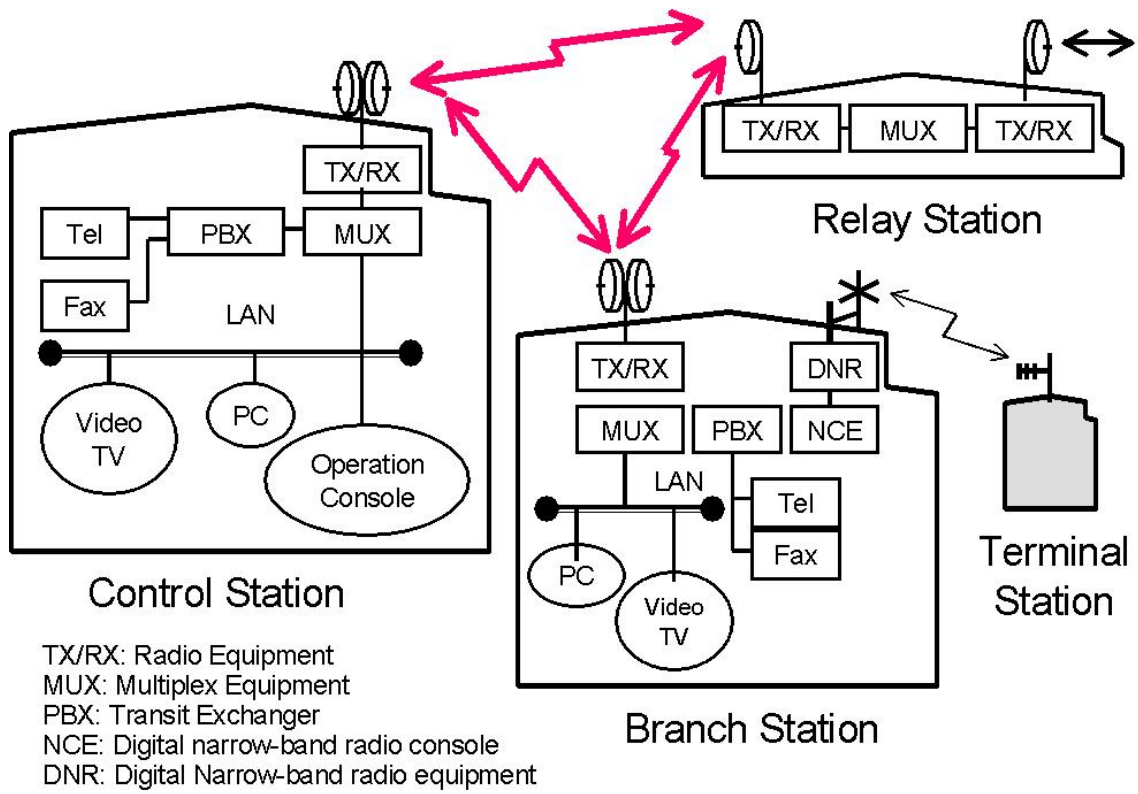

Fig. 2-1-2
Terrestrial System Configuration

3 System Requirements

3.1 Communication Modes

Communication modes of the terrestrial network system are required to include simultaneous, group, and individual communications between a terminal at the disaster site and Branch Station, or between a Control Station and a Branch Station, as shown in Table 2-1-1.

Table 2-1-1
Communication Modes

Communication Mode	Definition
Simultaneous Communication	Simultaneous one-way communication from the Control Station or Branch Station to some designated Branch Stations or Terminals.
Group Communication	One-way communication between a Control Station and a group of Terminals.
Individual Communication	Bi-directional communication between: <ul style="list-style-type: none">• Control Station and Branch Station,• Any two Branch Stations,• Control Station and any Terminal, or• Any two Terminals

3.2 Frequency Band

For the Backbone Line, an appropriate frequency band between the millimeter-wave and microwave bands is to be selected in consideration of service area size, cost-effectiveness, radio wave propagation, and channel capacity. The VHF/UHF bands are preferable for the Branch Line.

3.3 Multiple Access Method

TDMA (Time Division Multiple Access) should be used as the multiple access method for the branch line. Measures to prevent congestion in an emergency situation are required.

3.4 Transmission Capacity

Transmission capacity of the backbone line should be determined with consideration of effective traffic and economical transmission of voice, FAX, and image data.

3.5 Transmission Speed

Transmission speed of the Backbone Line should be determined to accommodate the multiplexing of voice, data, images and video. Typical media transmission speeds are denoted in Table 2-1-2.

Table 2-1-2 Typical Media Transmission Speeds

Media	Transmission speeds
Voice	64 kbps/32kbps
Small-capacity data	64 kbps
Image and video	384 kbps

3.6 Modulation Scheme

A modulation scheme should be determined to ensure efficient use of the radio frequency band and radio wave propagation conditions of the terrestrial system. Specific examples are: 4PSK (Phase Shift Keying), 16QAM, 64QAM or 128QAM.

3.7 QoS (Quality of Service)

Typical transmission Bit Error Rate (BER) is as follows:

- (a) For the Backbone Line: better than 1×10^{-4} in the worst case.
(The BER should respectively be better than 1×10^{-6} for 6Mbps, and 4×10^{-7} for above 13 Mbps.)
- (b) For the branch line: better than 1×10^{-4}
(The line reliability is to be above 95%.)

4 System Management Function

4.1 Monitoring Function

The control Station should be able to monitor status of equipment and network operation. The console in the station should feature a warning alarm. Equipment monitoring should be based on the existing open standard protocols, for example, SNMP (Simple Network Management Protocol), which provides the following management performance:

- Execution status monitoring for the equipment connected to the network
- Execution of the service status monitoring
- Execution of fault trap and performance management
- Network traffic monitoring
- Specific message recording on the system log

The warning alert messages should be recorded and stored in the network system's database.

4.2 System Redundancy

For the system redundancy, the terrestrial radio system should have a looped radiocommunication link that provides reliable communication utilizing alternative radio routes.

In case there is a communication malfunction in the radio link, the system should automatically isolate the faulty link and quickly switch to a alternate link.

The main equipment composing the Backbone Line should feature a redundant configuration. The main transmitter and/or receiver should be able to be switched automatically to the stand-by transmitter and/or receiver in case of failure. Remote-manual switching control of the transmitter or receiver should be possible within the Control Station.

PART 2

Satellite Network System

1. Overview

The satellite communication network in this system is intended to provide a reliable communication link via satellite between national Disaster Management Center (Agency), local disaster management centers (Control Stations) of the prefectural (or provincial or state) government, branch offices, etc, for collection of disaster information and for immediate notification of such information to every terminal. The network is designed to provide flexible and quickly deployable emergency and day-to-day telecommunication applications anywhere including remote areas and isolated islands. The application comprises point-to-point individual communication (voice, fax, and low-speed data), high-speed IP data, point-to-multipoint IP multicasting and video transmission. Figure 2-2-1 diagrams the overall system.

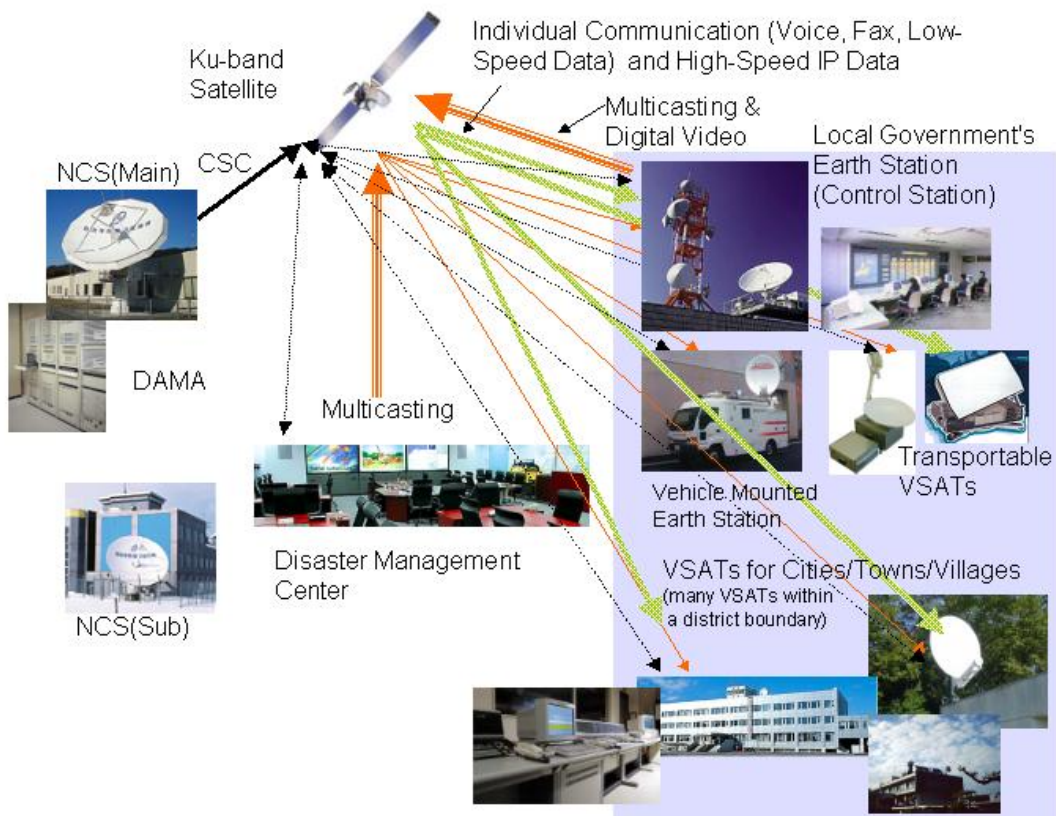

Fig. 2-2-1 Satellite Communication System Overview

In addition to use in day-to-day telephone/fax/data communication, the network can be utilized in the following situations:

- 1) Emergency contact and multicasting in a time of disaster, and transmission of images from the disaster area

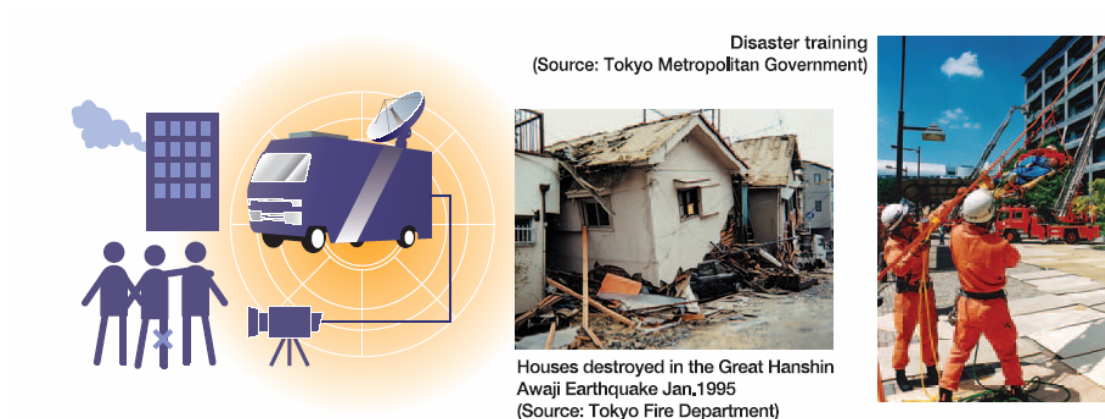

Fig. 2-2-2a Multicasting and Video Transmission

- 2) Distribution of a range of administrative information, such as live broadcasting of nationwide meetings and events, introduction of national policies, statements by regional governors, or Diet deliberations



Fig. 2-2-2b Distribution of Administrative Information

- 3) Nationwide transmission of images introducing festivals, expositions and special products of each of the regions



Fig. 2-2-2c Nationwide Transmission of Community Events

2 Basic System Structure

2.1 System Configuration

As shown in Figure 2-2-1, the satellite communication system should basically comprise a Ku-band satellite, the local governments' fixed earth stations (hereafter referred to as Control Stations) with a 4.5-meter class antenna, VSAT terminals with 1-2 meter antennae, and NCS (Network Coordination Station) and Sub-NCS. The NCS includes a SCPC-DAMA (Demand Assignment Multiple Access) system that allows effective use of the satellite transponder bandwidth by dynamic allocation of resource frequencies in response to on-demand requests from the earth stations, enabling both full mesh and star communication via satellite.

The earth stations including VSATs should consist of antenna, transmit-and-receive equipment (or ODU in case of VSAT), modems and terminal equipment. The NCS station should further be equipped with a satellite network management system including DAMA, multicasting equipment, digital video transmission-and-receive subsystem, IP/video transmission reservation subsystem, and the like.

2.1.1 NCS Station/Sub-NCS Station

The NCS Station provides the major control and management of the entire satellite network. The DAMA in the NCS should provide the following satellite resource management:

- 1) Assignment of traffic channels in response to on-demand or reservation request,
- 2) Communication controls for:
 - a) Priority channel assignment for particular disaster area
 - b) Setup for hotline connection
 - c) Forced disconnection of the non-urgent satellite channels in use in the event of disaster to ensure more important emergency communications

- 3) Reservation management for video transmission
- 4) Traffic volume monitoring,

The NCS also provides remote control and status monitoring of all earth stations, IP multicast and digital video transmission management, billing management, and the like.

Upon request from the Control Station or Branch Station, the NCS should be able to transfer some communication control functions to these stations.

The Sub-NCS station should provide a backup function for the NCS in case of scheduled maintenance of the NCS, or equipment failure in the NCS, or heavy rain around the NCS district. The NCS and Sub-NCS stations should be geographically dispersed to provide robustness against natural disasters such as earthquakes and typhoons.

2.1.2 Control Station (Local Government Station)

The Control Station should be located in the local (prefectural or provincial) government building to provide individual communication (voice/fax), multicasting in its district, and nationwide digital video transmission. These facilities should have the functions of status monitoring of the VSATs in its district boundary, and communication control in the event of disaster such as forced disconnection of the non-urgent satellite link to ensure more important emergency communication.

2.1.3 Branch Station

The Branch Stations should generally be located in the branch office of the local government, and provide individual communication (voice/fax) and IP data coupled with of a multicast data and digital video receiving function.

2.1.4 VSAT

The VSAT terminals should generally be located in the city/town/village government offices, disaster management departments, and in other public safety and rescue entities, and provide communication (voice/fax) and IP data coupled with a multicast data and digital video receiving function.

2.1.5 Vehicle Mounted Station

A vehicle mounted station like a SNG vehicle is suitable to support individual communications in the disaster area, or urgently transmit disaster image from the damaged area. It should provide digital video, voice and fax communications with the option of IP data transmission.

2.1.6 Transportable VSAT

A lightweight, transportable VSAT with a small dish, with its primary power being supplied by a portable engine generator, is suitable for emergency communication in the disaster area. It should provide voice and fax communication with the option of IP data transmission.

2.2 Satellite Network Configuration

The disaster management communication system manages both the traffic of point-to-point individual communication (voice, fax and data) and point-to-multipoint multicasting of disaster-related information including video. Each earth station or VSAT is capable of providing communications either in a mesh (for voice) or star (for multicast) topology or both, within the limitation of its transmit-and-receive capability of the equipment, number of useable modems, and other factors.

The proposed network configuration is designed to allow a mixed operation of full mesh and star topology as shown in Figure 2-2-3. The SCPC DAMA system controls the entire network operation and traffic management. For point-to-point individual communications, the system uses SCPC/FDMA multiple accessing. The Common Signaling Channel (CSC) in a TDM/TDMA scheme is used for calling of channel requests from the earth station to NCS and for channel assignment responding from the NCS to the requesting station.

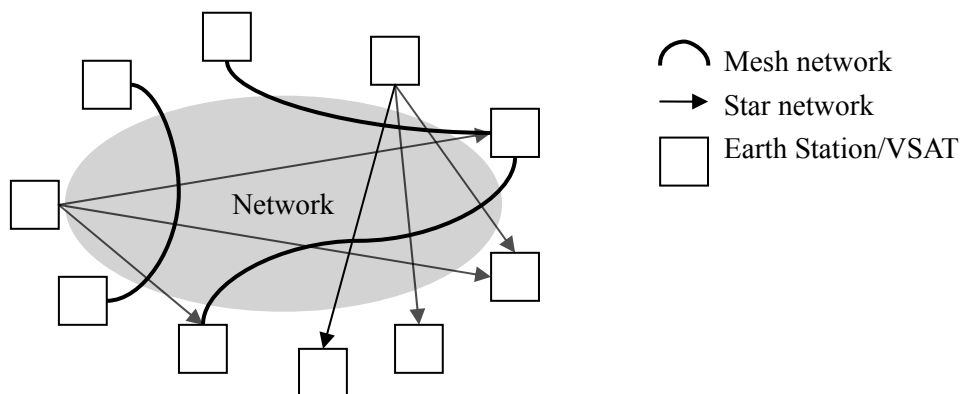

Fig. 2-2-3 Mesh and Star Topologies for Disaster Management Communication

3 Applications

The system should provide the following applications:

- 1) Individual communication for transmission of voice, fax and data at the information rate of 32kbps
- 2) Point-to-multipoint multicasting at the information rate of 32kbps
- 3) IP transmission at the information rate from 32k to 8Mbps
- 4) Digital video (MPEG-2) transmission at 7.3Mbps

For point-to-point communication, a hotline communication and priority communication should be available in the event of a disaster, in addition to the individual communication in the normal operation.

Table 2-2-1 shows typical applications and network configuration of the system.

Table 2-2-1 Satellite Applications and Network Configuration

Applications	Communication Link	Network	Channel (Frequency) Assignment
Individual Communication (voice, fax, or low-speed data)	Between any two earth stations (VSATs)	N:N mesh	DAMA (Demand Assigned)
Multicasting (Voice, fax, low-speed data, or IP type data)	1) From Central Disaster Management Agency to local government (e.g., prefecture), or local disaster management department 2) From a local government to cities/towns/villages in the district boundary	1:N Star	PA (Pre Assigned)
IP Data Communication	Between any two earth stations (VSATs)	N:N mesh, 1:N Star	DAMA (On Demand or Reserved)
Digital Video (MPEG-2)	From transmit earth station to receive earth stations equipped with IRD	1:N Star	DAMA (Reserved)

3.1 Individual Communication

The individual communication provides a dedicated service of voice, fax and low-speed data at the information rate of 32kbps between any two users in the network. The system uses SCPC for full mesh connection. The DAMA, upon receipt of a call, assigns a pair of available channels for the individual users via CSC (Common Signaling Channel). Once the call is completed, the channels are immediately returned to the resource channel pool for the next assignment to another call. The DAMA system comprises the DAMA Control equipment of the NCS and CSC modem of the other earth stations. The CSC modem assigns transmit and receive channels (frequencies) to the SCPC modems in accordance with channel assignment by the NCS DAMA.

3.2 Multicasting

Multicasting from the Control station (local government) or from the Disaster Management Agency to the designated earth stations is available by transmitting of instructions by voice, fax, data, or IP data using the fixed channels that are allocated to each Control station and Disaster Management Agency. The receiving station should be able to receipt notification.

3.3 IP Data Communication

The point-to-point IP data communication is available between any two earth stations that are capable of IP data transmission in the network with an information rate from 32 kbps to 8 Mbps. The satellite communication bandwidth for IP data communication is usually unsymmetrical with a variable transmission rate due to transmission capability of the other end earth station. Upon request from an earth station, The DAMA control equipment of NCS assigns the transmission rate (bandwidth) and channel (frequency) via CSC channel to the transmit and receive earth stations by way of Demand Assignment Multiple Access/Bandwidth On Demand (DAMA/BOD). Instant and reserved channel assignments are both available for IP data communication. In the latter case, the requesting earth station accesses the NCS transmission reserve server.

3.4 Digital Video Transmission

The MPEG-2 video transmission is available from the transmit earth station to the receive earth stations equipped with an Integrated Receiver-Decoder (IRD) having the same scrambling key for conditional access as that of the transmit station.

This application is made available through the reservation system of the NCS.

3.5 Communication Control

In order to ensure important emergency communications in the event of disaster, the NCS and Control stations should have a communication control function i.e., priority channel assignment for a particular disaster area, setup for hotline connections and forced disconnections of the non-urgent satellite channels in use. In addition, the telephone exchanger of the Control station should provide congestion control for the outgoing and incoming calls in case of disaster to ensure emergency communication lines.

4 Technical Specifications

4.1 Frequency Band

Considering the frequencies being used by the Asia Pacific region satellites, the C-band or Ku-band is suitable for the satellite network system. From the viewpoint of inexpensive equipment cost and its availability on the worldwide market, and smaller size and weight of the transportable VSAT, the use of the Ku-band may be preferable. The rain attenuation calculations are found in the Recommendations ITU-R P.618 and S.1432.

4.2 Multiple Access

The Demand Access Multiple Access (DAMA) is suitable for the large scaled VSAT network due to the make of the mixed services of many narrow-band individual communication channels, and point-to-multipoint IP multicasting/digital video transmission.

4.3 QoS (Quality of Service)

The QoS of the satellite channels in terms of transmission BER should be better than 1×10^{-6} for 99.8 % of time in the worst month in order to ensure emergency communication.

(Reference: Recommendation ITU-R S.1062)

4.4 Link Budget and Transmission Capability

This satellite communication system is intended for use in disaster recovery, thus it should have high availability and reliability. Such a system usually requires a large diameter antenna that may result in a high implementation cost. The VSAT is, instead, suitable for a large number of terminals for towns and villages with small traffic because the VSAT is inexpensive and generally needs neither a radio station license nor dedicated operating personnel holding radio licenses. Since during disaster recovery, most communications should be done between Control Station (local government) and each town or village, the link budget should be designed to

provide high availability for the individual communication channels.

5 Network Control and Monitoring

The NCS should perform a centralized management of the entire network for:

- 1) Remote control and monitoring of all earth stations including VSATs
- 2) Monitoring and event logging of satellite network operation
- 3) Traffic statistics
- 4) Traffic congestion control
- 5) Billing management

The Control earth station should be also able to remotely monitor operating status and control the earth stations located within its district boundary using multicasting channel assigned to the Control station.

5.1 Network Control and Monitoring by NCS

5.1.1 Health Check of Earth Stations

In response to periodic requests from the NCS via the dedicated channel, the CSC modem of every earth station should transmit the health check information of all modems (in operation/in standby/in maintenance/in fault). The NCS can designate a specific earth station to execute an individual health check if necessary.

5.1.2 Remote Controls to Earth Stations

Using the CSC channel, the NCS should be able to execute forced disconnection from the network to every modem of the earth stations, and also execute ON and OFF controls to the ODU of any VSAT when some abnormal situation is found, e.g., some VSAT's do not get off the line after a call is completed, or some spurious radiation is found in the spectrum monitoring.

5.1.3 Monitoring of Satellite Network Operation

The NCS should be able to monitor the satellite network's channel frequencies, earth stations and satellite modems being used, on a service basis, communication channel basis and transmission rate basis. The NCS should also monitor the assignment status of priority channels, hot-line channels, unused channels, etc.

5.1.4 Traffic Statistics

The NCS should monitor, store in the database and retrieve with desired conditions from the database, the traffic information such as the number of calls, call loss probability, communication airtime and data volumes in any period of time.

5.1.5 Traffic Congestion Control

The NCS-DAMA should examine traffic congestion of the CSC (up-link) by counting the retry numbers of the CSC (up-link) signal. If it is judged that CSC (up-link) is congested, the DAMA should search for the next CSC (up-link) channels and re-transmit the CSC (up-link) by manual intervention.

The NCS should also be able to provide stop and re-transmission controls of the CSC (up-link) channels via CSC (down-link) channel.

5.2 Control and Monitoring by Control station

The Control station (located in a local government) should be able to remotely monitor the op-

erating status and to remotely control the earth stations located within its district boundary (e.g., prefecture) via multicasting channel, from the centralized control and monitoring equipment associated with status monitoring display. The Branch Office Station, upon NCS's authorization, should also be able to remotely monitor and control the earth stations (VSATs) within its district boundary.

Appendix A to ANNEX 2

Example of Systems in Japan

This appendix provides the technical specifications of the core network system for disaster management in Japan as a typical example. The satellite system is included in Recommendation ITU-R S.1001.

A.1 Core Terrestrial System

Frequency band	6.5 GHz/7.5 GHz/12 GHz/40 GHz band
Transmission speed	1.5 – 208 Mbps
Modulation scheme	4PSK ^{*1} /16QAM ^{*2} /64QAM/128 QAM

*1: Phase Shift Keying

*2: Quadrature Amplitude Modulation

A.2 Branch Terrestrial System

Frequency band	VHF/UHF band
Channel spacing	25 kHz
Multiple access method	TDMA ^{*1}
Transmission speed	32 kbps/8 kbps
Modulation scheme	$\pi/4$ shift QPSK ^{*2}

*1: Time Division Multiple Access

*2: Quadrature Phase Shift Keying

A.3 Satellite system

Summary of Channel Parameters of Satellite Network

Type of Service		Multiple Access	Modulation	Information Rate
Individual Communication (Voice, FAX, low-speed data)		SCPC/DA-FDMA	QPSK (Continuous or Burst)	32 kbps
Multicasting (Voice, FAX, low-speed data)	Up	PA-TDMA/FDMA	QPSK (Burst)	32 kbps
	Down	PA-FDMA	QPSK (Continuous)	32 kbps
IP Transmission	Up	SCPC/DA-FDMA	QPSK (Continuous)	32kbps –8Mbps
	Down	DCPC/DA-FDMA	QPSK (Continuous)	32kbps –8Mbps
Digital Video Transmission		SCPC/DA-FDMA	QPSK (Continuous)	7.3Mbps
Common Signal- ing Channel	Up	RA-TDMA/FDMA	QPSK (Burst)	32kbps
	Down	PA-TDMA/FDMA	QPSK (Continuous)	32kbps

Typical Antenna Diameter for Various Earth Stations

Earth Station Standards	Antenna Diameter	Earth Stations					
		NCS/ Sub-NCS	Control station (Local Government)	Branch Offices	Cities /Towns /Villages	Vehicle Mounted	Transportable
STD-A	7m	X	X				
STD-B	4.5m		X				
STD-C	3.6m		X	X			
STD-D (VSAT)	2.4m			X	X		
STD-E (VSAT)	1.8m			X	X		
(Vehicle mounted)	1.8m					X	
STD-F (VSAT)	1.2m			X	X		
(Vehicle mounted)	1.2m					X	
STD-G (VSAT)	0.75m			X	X		
STD-H (VSAT)	0.6m			X	X		
STD-J (Transportable VSAT)	0.75m						X
STD-K (Transportable VSAT)	Planar type						X

IP data and Video Transmission Capability

		IP data transmission (variable rate)	Digital video (MPEG-2)	
			Transmitting	Receiving
Earth Station Standards	STD-A	32 – 8191 kbps	×	×
	STD-B		×	×
	STD-C		×	×
	STD-D	32 – 2048 kbps	×	×
	STD-E		-	×
	STD-F		-	×
	STD-G		-	×
	STD-H	-	×	
	STD-I	-	-	×
	STD-J	32 – 2048 kbps	-	×
	STD-K		-	×

NOTE: The data transmission rate may become smaller by rainfall rate in case of smaller diameter antenna.

ANNEX 3

Guidelines for Safety and Reliability Measures on the use of Disaster Management Communication Systems

1 Scope

This Annex provides guidelines to promote safety and reliability measures that should be taken in implementing disaster management communication systems in order for such systems to form a dependable network in disasters. The guidelines involve the following areas:

- Outdoor/indoor equipment for disaster management communication network;
- Management of designing, maintenance and operation of disaster management communication network.

Guidelines for above items are described in sections 2 and 3, respectively.

2 Guidelines for Communication Equipment

2.1 General rule

Items	Measures
(1) De-concentration of communication centers	Key communication centers up to avoid adverse affects or network functions should be geographically dispersed and back each other.
(2) Installation of alternative connection	Connection between two important communication centers should have an alternative route via another center.
(3) Establishment of different transmission path equipment	Important optical transmission path should promote two-fold routing by installing loop topology, etc.
(4) Dispersing accommodation of telecommunication lines	Accommodation of communication lines between important communication centers should be distributed over different transmission path equipments.
(5) Installation of backup telecommunication line	Important transmission paths should have backup communication line and be able to switch when necessary.

Items	Measures
(6) Monitoring of operating conditions of information communication network	(a) Function to monitor operating conditions of important transmission equipment and to detect and report failure immediately should be installed.
	(b) Switching equipment should have functions to monitor traffic, to report extraordinary congestion immediately, and to limit user access when necessary.
(7) Improvement of software credibility	(a) Quality of software should be examined before installation.
	(b) Measures to avoid simple mistakes made in changing software and data should be taken.
	(c) Important data such as system data should be recovered when necessary.
	(d) Software should have functional ability to detect and report anomalies immediately.
(8) Information security measures	(a) Measures should be taken against computer viruses and malicious programs.
	(b) Measures to decrease electromagnetic emission or to mask electromagnetic leakage should be taken in order to avoid important information leakage from the computer operating and managing networks.
	(c) A communication network that treats communications requiring identification and confirmation of users should have functions to identify and confirm proper users.
	(d) Measures against system destruction and data theft should be taken such as restricting accessible data region and executable commands.
	(e) Function to reject passwords using only common words should be installed.
	(f) Access history above a certain number of access requests should be maintained.
	(g) Functions to record access requests to important information that needs protecting should be installed.
	(h) Measures to maintain secrecy of communication should be taken when necessary such as encryption.

Items	Measures
	(i) Criteria for crosstalk attenuation should be set.
	(j) Measures to avoid illegal use of network should be installed.
(9) Measures to communication blackout	Measures to avoid communication breakdown should be installed.
(10) Emergency and recovery measures	(a) Emergency and recovery measures such as stocking cables for temporary use should be taken for important transmission equipment.
	(b) Emergency and recovery measures should be taken such as storing switching equipment for mobile communication.
	(c) Ad hoc telephone line by radio equipment such as satellite earth station should be able to be installed in emergencies.
	(d) Ad hoc two-way telecommunication link using radio equipment should be able to be set up in case the line between mobile base station and switching station is disconnected.
	(e) Ad hoc telecommunication link by transportable radio stations should be able to be set up in case mobile communication base stations are damaged.
	(f) Ad hoc telecommunication link by backup equipments should be able to be set up in case that it is extremely difficult to communicate when other transmission equipment is damaged.

2.2 Outdoor equipments

Items	Measures
(1) Measures against wind damage	Measures to avoid damage by strong wind or vibration caused by wind should be taken where equipment may receive wind pressure.
(2) Measures against vibrations	Measures to avoid failure by vibration caused by earthquake should be taken.
(3) Measures against lightning damage	Measures against damage caused by lightning for outdoor equipment should be taken where lightning damage is likely to occur.
(4) Measures against fire disaster	Measures to fireproof outdoor equipment should be taken where fire disasters may occur.
(5) Water resistance	(a) Water resistance should be set for outdoor equipment located in water.
	(b) Measures to avoid failure as a result of water pressure for outdoor equipment located in water should be taken.
(6) Measures against flood damage	Important outdoor equipment should not be installed where flood damage is likely to occur.
(7) Measures against freezing	Measures to avoid failure as a result of frozen outdoor equipment located where freezing may occur should be taken.
(8) Measures against salt damage	Measures to avoid failure as a result of salt corrosion, corrosive gas or dust for outdoor equipment should be taken where this type of damage could occur.
(9) Measures against extreme temperature	(a) Outdoor equipment located in very high or low temperatures should work stably under such conditions.
	(b) Outdoor equipment located in places with extreme temperature swings or an environment with immediate temperature changes should work stably under such conditions.

Items	Measures
(10) Measures against high humidity	Measures against high humidity and rust on outdoor equipment should be taken such conditions are prevalent.
(11) Prevention of third party access	(a) Measures to prevent third parties from touching equipment should be taken.
	(b) Measures to avoid incursions such as locking underground tunnels accommodating communication cables should be taken.
(12) Detection and report of failure	(a) Functions to detect and report failure immediately should be installed for important outdoor equipment.
	(b) Functions to spot failure points should be installed for important equipment.
(13) Assignment of backup equipment	Measures to assign backup or alternative equipments for important equipment should be taken.
(14) Laying communication cables underground	Laying communication cables underground should be promoted to avoid damage from collapsing of buildings and fire disasters.

2.3 Indoor equipment

Items	Measures
(1) Earthquake countermeasures	Measures to prevent equipment from falling down or moving and to prevent equipment parts from causing contact failure or falling away by normal earthquakes should be taken.
(2) Measures against lightning damage	Measures to avoid lightning damage for important indoor equipment should be taken where such damages may occur.
(3) Measures against fire disasters	Measures to fireproof indoor equipment should be taken where fire disasters may occur.
(4) Reliability	(a) Redundancy or alternative measures should be taken for important indoor equipment.
	(b) Immediate switch to backup equipment should be done for important indoor equipment.
(5) Detection and reports on failure	(a) Functions to detect and report failures immediately should be installed for important indoor equipment.
	(b) Remote control functions should be installed for important unmanned indoor equipment.
(6) Assignment of testing equipment	Testing or alternative equipment should be prepared.
(7) Assignment of spare equipment	Measures to assign backup or alternative equipments for important equipment should be taken.

2.4 Electric supply facility

In addition to guidelines for indoor equipment, the following items should be taken into account for electric supply facilities.

Items	Measures
(1) Power supply condition	(a) Power supply for communication network should be stable.
	(b) Measures to keep power voltage and frequency within permissible levels should be taken.
(2) Measures against blackouts	Any of the following should be installed; <ol style="list-style-type: none"> 1) backup power generator 2) rechargeable battery 3) multiple power supply systems 4) portable power supply equipment

3 Guidelines for Management

3.1 Management of network design

Items	Measures
(1) Clarification of framework	Framework of design management such as decision-making, work sharing and scope of responsibility should be clarified.
(2) Clarification of design guidelines	(a) Basic network functions should be clarified.
	(b) Design network should be considered in future expansion of scale and upgrading of functions.

3.2 Network security and operational management

Items	Measures
(1) Clarification of framework	Security and operational management framework of work sharing, communication system and scope of responsibility should be clarified.
(2) Set of criterion	Security and operational criterion should be set. Security

Items	Measures
	should be managed and operational data should be collected.
(3) Working procedure	Security and operational work procedures should be set.
(4) Monitoring, security and control	(a) Operating condition of equipment should be monitored. In case of failure, measures to change preparative equipment or to make repairs should be taken as occasion demands.
	(b) Operating condition of communication network should be monitored and measures such as connection inhibited should be taken.
(5) Relegating of security and management	(a) In case of outsourcing security, scope of security work and responsibility should be clarified under consignment contract.
	(b) In case of outsourcing security, work procedure should be clarified and monitored.

3.3 Renewal and relocation management of equipment

Items	Measures
(1) Clarification of framework	Management framework of work sharing, communication system and scope of responsibility should be taken.
(2) Clarification of working process	Working process should be clarified and managed.

3.4 Information security management

Items	Measures
(1) Establishment of security policy	Security policy should be established and reviewed accordingly.
(2) Establishment of contingency plan	Contingency plan defining measures to counter illegal access should be established and reviewed accordingly.
(3) Information gathering in information security	Obtaining technical information and industry trends on the latest information security and reflecting it in secu-

Items	Measures
	rity measures should be undertaken.
(4) Persons with specialized knowledge and skills	Persons with qualifications or with specialized knowledge and skills about information security should be hired.

3.5 Data management

Items	Measures
(1) Clarification of framework	Data management framework of work sharing, communication system and scope of responsibility should be clarified.
(2) Set of criterion	Criterion of data management should be set.
(3) Working procedure	Setting of working procedure for data handling should be set.
(4) Data management	(a) Data concerning specification and location of equipment and user's data should be categorized and managed according to property.
	(b) Confidential range of workers for data of equipment specification and location and user's data should be clarified, familiarized and ensured.
	(c) User's code numbers should be protected.

3.6 Environmental management

Items	Measures
(1) Building stability	Stability check of building should be regularly performed.
(2) Security of air conditioning equipment	Stability check of air condition equipment should be regularly performed.

3.7 Security management

Items	Measures
(1) Clarification of framework	Security framework should be clarified.
(2) Management procedures	Procedures for security management should be set.
(3) Entry and out control in buildings or communication equipment compartments	Entry and out control in buildings and communication equipment compartments should be executed.
(4) Management of keys and code numbers	Gateway key and code numbers should be managed.
(5) Management of security equipment	Maintenance check of security equipment should be regularly performed.
(6) Entry and out record custody	Entry and out records should be maintained for a certain period.

3.8 Response to emergencies

Items	Measures
(1) Clarification of framework	(a) Framework for emergencies such as communication system or scope of authority in emergencies should be clarified.
	(b) Framework of communication system between interconnected companies should be clarified.
	(c) Lay out of framework ensuring a communication method to concerned staff and assembly method for staff in emergencies should be undertaken.
	(d) Framework of extensive support should be clarified.
	(e) Communication system between country and concerned organizations in emergency support and recovery actions should be clarified.
	(f) Necessary measures should be taken to ensure communication method for support and recovery actions in emergencies.
(2) Recovery measure procedure	Recovery measure procedures should be undertaken.

Items	Measures
dures	

3.9 Education and training

Items	Measures
(1) Clarification of framework	Establishment of educational and training plan and implementation structure should be clarified.
(2) Education and training concept	(a) To clarify the objects of education and training and to modify plans in consequence of performance following the education and training should be undertaken.
	(b) Education and training in developing the knowledge and discretion natural in the smooth operation of a communication network should be undertaken.
	(c) Education and training to develop high-integrity work ability to input data should be undertaken.
	(d) Education and training for development of knowledge in equipment maintenance should be undertaken.
	(e) Education and training for disaster prevention should be undertaken.
	(f) Education and training for information security should be undertaken.

3.10 Survey analysis and improvement of actual conditions

Items	Measures
(1) Clarification of framework	Framework for survey analysis of actual conditions should be clarified regarding maintaining and operation of the communications network.
(2) Set of criterion	Criterion of items and assessment method for survey analysis of actual conditions should be set regarding maintaining and operation of the communications net-

Items	Measures
	work.
(3) Working procedures	<p>(a) Work procedures on survey analysis of actual condition regarding maintaining and operation of the communications network should be undertaken.</p> <p>(b) Results of survey analysis of actual conditions regarding maintaining and operation of the communications network should be reflected in the operating framework and procedure manual of the communication network as occasion demands.</p>
(4) Improvement	Results of survey analysis of actual condition regarding maintaining and operation of the communications network should be reflected in the educational and training plans as occasion demands.

(End of Document)